



US007551123B2

(12) **United States Patent**
Stagliano, Jr. et al.

(10) **Patent No.:** **US 7,551,123 B2**
(45) **Date of Patent:** **Jun. 23, 2009**

(54) **PHASE SHIFTED TRANSMITTED SIGNALS
IN A SIMULTANEOUS DUAL POLARIZATION
WEATHER SYSTEM**

4,323,898 A *	4/1982	Barnes et al.	342/188
4,323,899 A *	4/1982	Barnes et al.	342/188
4,684,951 A	8/1987	Baumer	342/362
4,821,039 A *	4/1989	Crane	342/149
4,868,917 A	9/1989	Woolcock	

(75) Inventors: **James J. Stagliano, Jr.**, Daleville, AL (US); **James Larry Alford**, Enterprise, AL (US); **James Rogers Helvin**, Enterprise, AL (US); **Dean A. Nelson**, Enterprise, AL (US)

(Continued)

FOREIGN PATENT DOCUMENTS

(73) Assignee: **Enterprise Electronics Corporation**, Enterprise, AL (US)

WO WO97/24629 A1 * 7/1997

(*) Notice: Subject to any disclaimer, the term of this patent is extended or adjusted under 35 U.S.C. 154(b) by 0 days.

(Continued)

OTHER PUBLICATIONS

(21) Appl. No.: **11/386,613**

Doviak, R.J., Bringi, A. Ryzhkov, A. Zahrai, D.S. Zrnice. "Considerations for Polarimetric Upgrades to Operational WSR-88D Radars." Journal of Atmospheric and Oceanic Technology, Mar. 2000, vol. 17, pp. 257-278.

(22) Filed: **Mar. 22, 2006**

(Continued)

(65) **Prior Publication Data**
US 2007/0222661 A1 Sep. 27, 2007

Primary Examiner—Bernarr E Gregory
(74) *Attorney, Agent, or Firm*—Russell Carter Gache; Maynard Cooper & Gale, PC

(51) **Int. Cl.**
G01S 7/28 (2006.01)
G01S 7/35 (2006.01)
G01S 13/95 (2006.01)
G01S 13/00 (2006.01)

(57) **ABSTRACT**

(52) **U.S. Cl.** **342/188**; 342/26 R; 342/82; 342/89; 342/175

A system for simultaneously propagating dual polarized signals in a polarimetric radar system includes a system for shifting the phase of one of the two signals. The simultaneous dual polarization weather radar transmits signals in both the horizontal and vertical orientations at the same time. Upon reception, the signals in each channel are isolated and a number of standard and polarimetric parameters characterizing atmospheric conditions are determined. The accuracy upon which these parameters can be determined depends partially upon the interference between these two channels. The system and method isolates the vertical and horizontal channels by using the phase information from the signals to minimize the interference.

(58) **Field of Classification Search** 342/26 R-26 D, 342/27, 28, 82-103, 175, 188-197, 361-366, 342/146-157; 343/850-853

See application file for complete search history.

(56) **References Cited**

U.S. PATENT DOCUMENTS

2,851,681 A *	9/1958	Cohn	342/361
3,049,703 A *	8/1962	Chester	342/26 R
3,111,668 A *	11/1963	Kuecken	342/361
3,568,190 A *	3/1971	Wong	342/188
3,849,780 A *	11/1974	Dynan	342/361

30 Claims, 4 Drawing Sheets

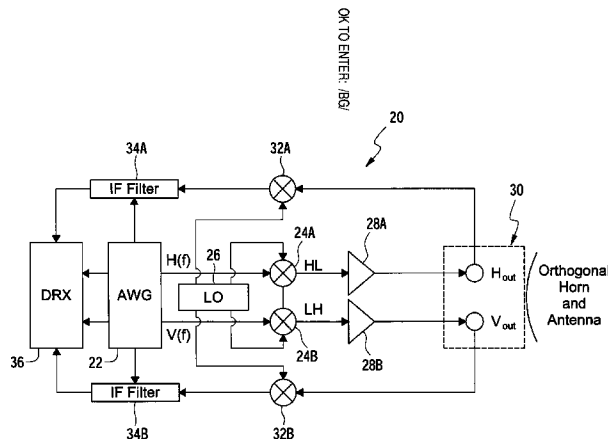

U.S. PATENT DOCUMENTS

5,231,404	A *	7/1993	Gasiewski	342/362
5,255,004	A *	10/1993	Berkowitz et al.	343/853
5,262,788	A *	11/1993	Drabowitch et al.	342/188
5,500,646	A	3/1996	Zrnic	342/188
5,621,410	A	4/1997	Gray et al.	
5,726,657	A	3/1998	Pergande et al.	342/202
5,793,334	A	8/1998	Anderson et al.	343/786
5,940,776	A	8/1999	Baron et al.	702/4
6,061,013	A	5/2000	Sauvageot et al.	
6,473,026	B1	10/2002	Ali-Mehenni et al.	
6,545,630	B1 *	4/2003	Apa et al.	342/188
6,646,599	B1 *	11/2003	Apa et al.	342/361
6,803,875	B1	10/2004	Alford et al.	
6,859,163	B2	2/2005	Alford et al.	
7,049,997	B2	5/2006	Alford et al.	
7,158,071	B2 *	1/2007	Testud et al.	342/26 D
7,196,654	B2 *	3/2007	Edwards et al.	342/188

FOREIGN PATENT DOCUMENTS

WO WO99/38028 A1 * 7/1999

OTHER PUBLICATIONS

Liu, Y., J.W. Conway, E.A. Brandes, A.V. Rzyhkov, J. Vivekanandan, D.S. Zrnic, and R. Oye. "The Use of Polarization Data in the Opera-

tional Identification of Hydrometeor and Non-hydrometeor Targets." Preprints, 29th Conf. Radar Meteor. Montreal, Canada: American Meteorological Society 1999: pp. 178-179.

Rzyhkov A., R. Lopez, R. Fulton, D. Zrnic, T. Schuur and Y. Liu. "Hydrometeor Classification with a Polarimetric Radar for Improved Rainfall Measurements and Detection of Hail and Electrically Charged Regions." Preprints, 29th Conference on Radar Meteorology. Montreal, Canada: American Meteorological Society, 1999: pp. 289-292.

Next Generation Weather Radar Program Operational Support Facility.

Vivekanandan, J., D.S. Zrnic, S.M. Ellis, R. Oye, A.V. Rzyhkov, and J. Straka "Cloud Microphysics Retrieval Using S-band Dual-polarization Radar Measurements." Bulletin of the American Meteorological Society 1999: pp. 381-388.

Zahrai Allen and Dr. Dusan Zrnic. "Implementation of Polarimetric Capability for the WSR-88D (NEXRAD) Radar." Long Beach, CA. American Meteorological Society 1997.

Zrnic, D.S., and A.V. Rzyhkov. "Polarimetry for Weather Surveillance Radars." Bulletin of the American Meteorological Society 1999: pp. 389-406.

Zrnic, D.S. Zahrai, A., Doviak, R.J., Carter, J., and Torres, S. "Polarimetric Upgrades of the NOAA's WSR-88D Research and Development Radar." 7.14.

* cited by examiner

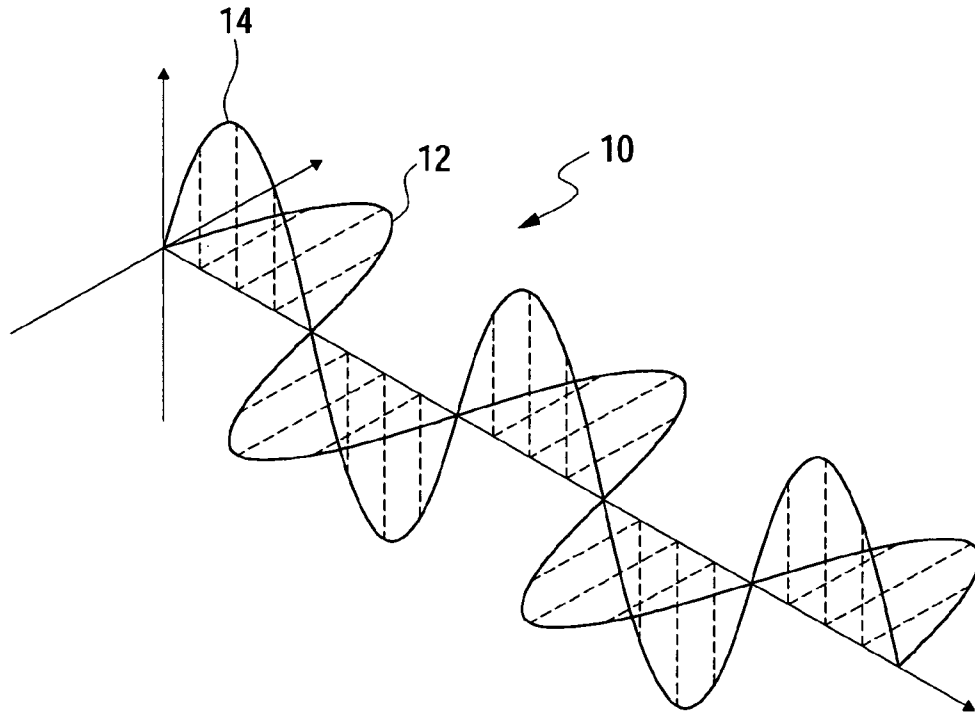

FIG. 1A

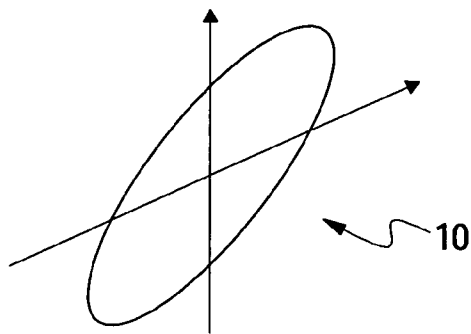

FIG. 1B

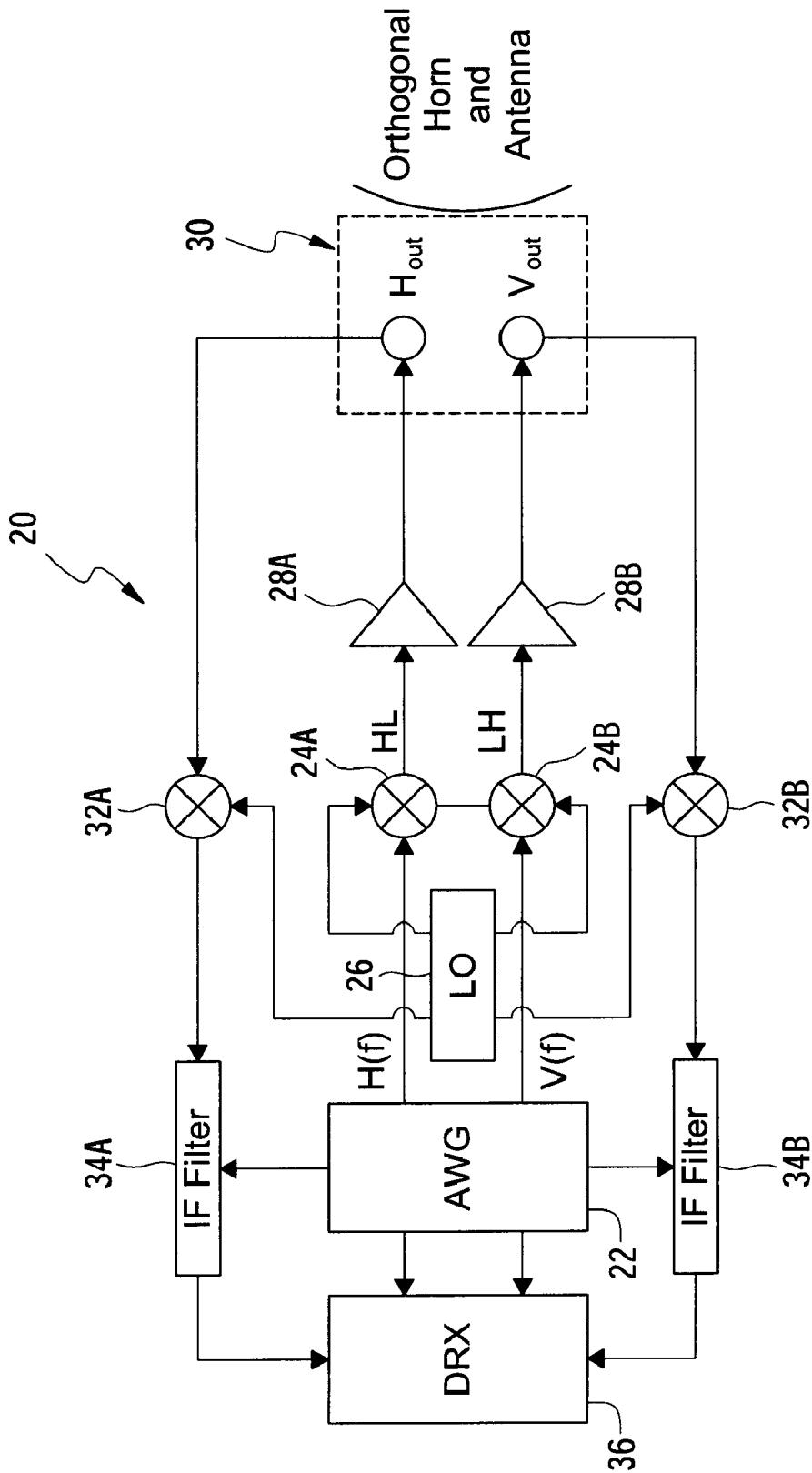

FIG. 2

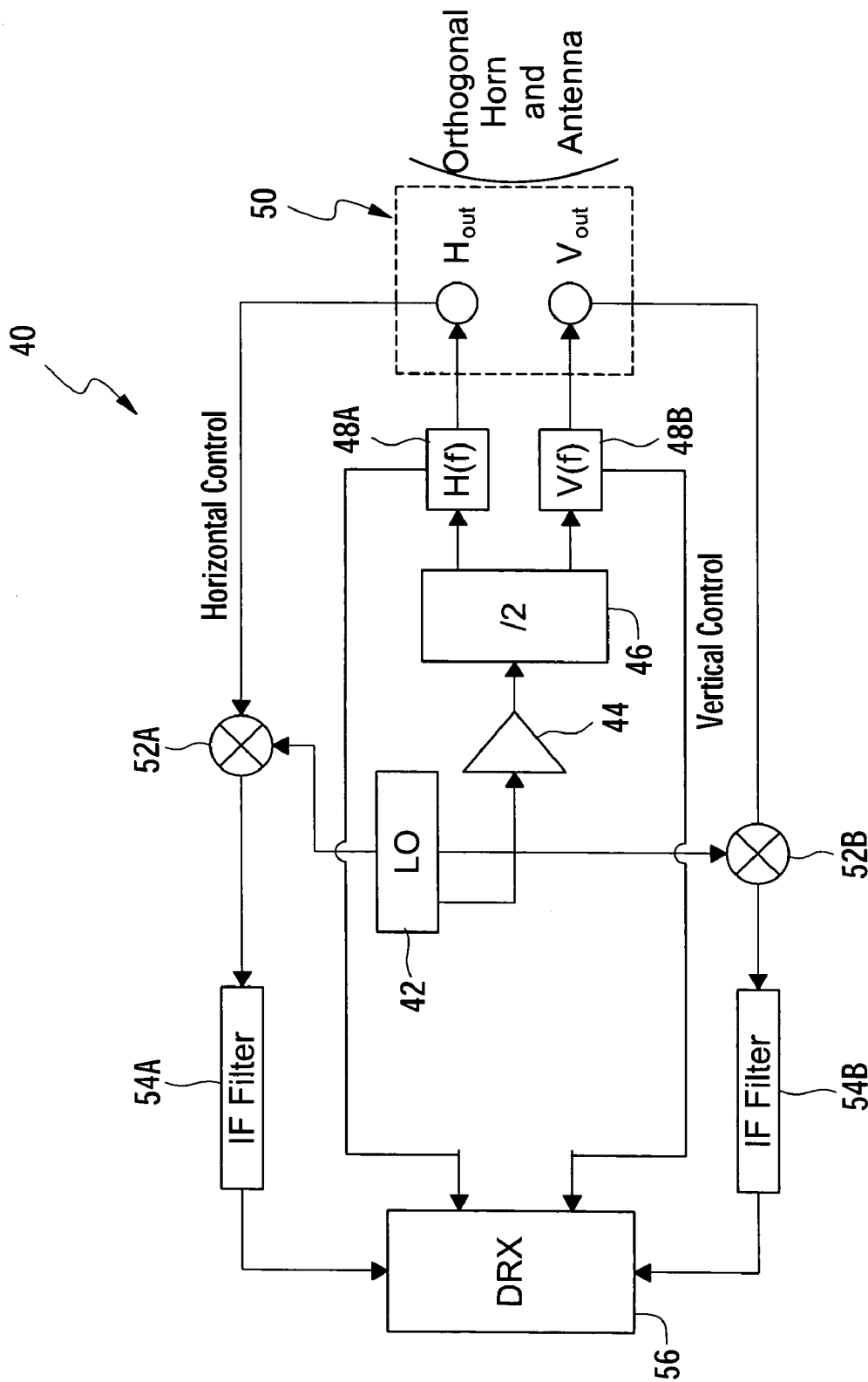

FIG. 3

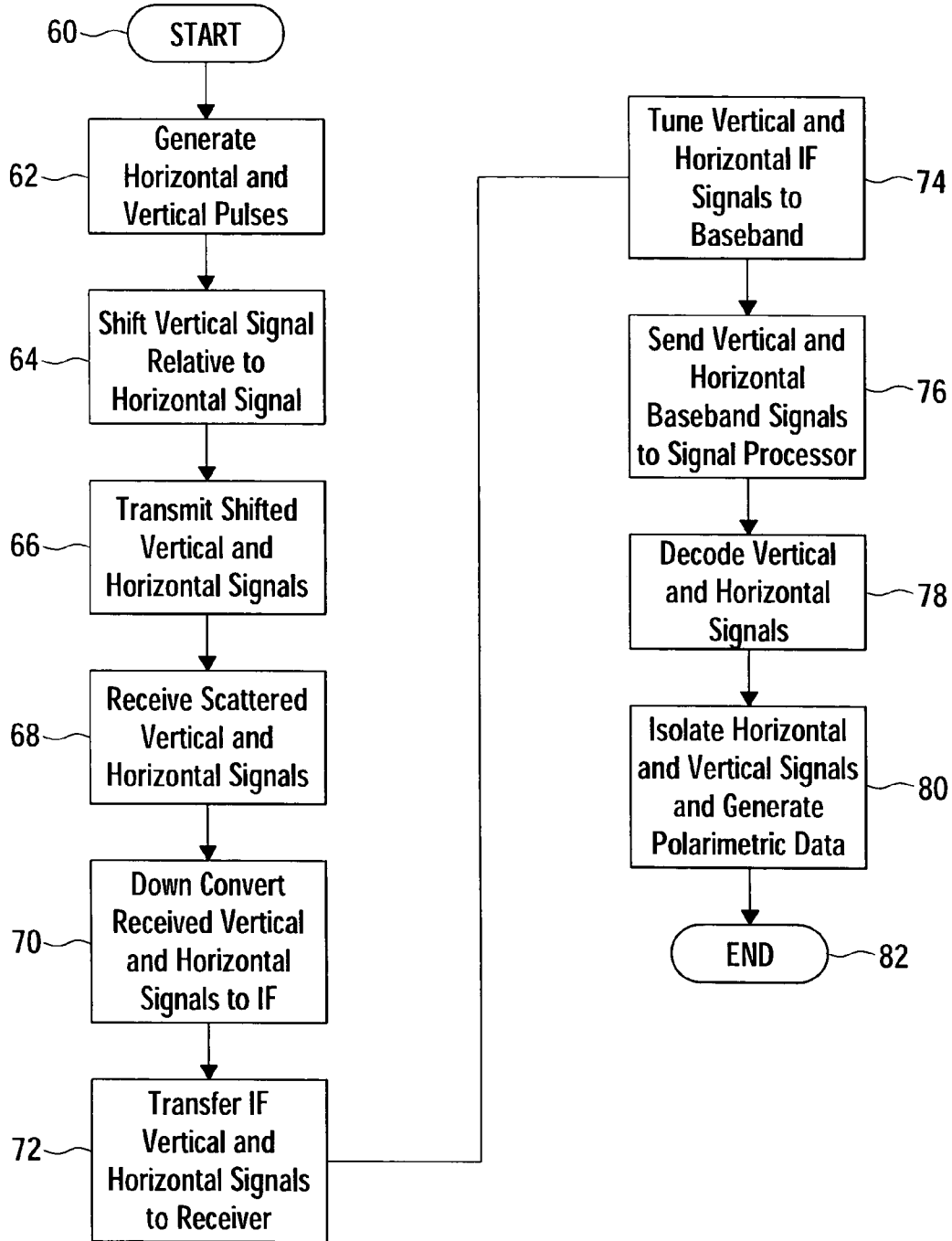

FIG. 4

PHASE SHIFTED TRANSMITTED SIGNALS IN A SIMULTANEOUS DUAL POLARIZATION WEATHER SYSTEM

TECHNICAL FIELD

The present invention relates generally to weather radar systems. Particularly, the present invention relates to Doppler weather radar systems utilizing dual polarization to enhance reflectivity resolutions of liquid hydrometeors.

BACKGROUND OF THE INVENTION

The majority of weather radar systems in operation today utilize a single polarization strategy to enhance precipitation reflectivity. Liquid hydrometeors (e.g. raindrops) deviate from a sphere when their radius is greater than about 1 mm and have a shape more like that of an oblate spheroid with a flattened base (similar to a hamburger bun) that gives a slightly stronger horizontal return. Hence, current radar systems are typically horizontally polarized to enhance precipitation returns.

However, singly polarized radar systems have severe limitations in regions with partial beam blockage and such systems do not facilitate hydrometeor classification. To overcome these shortcomings of singly polarized weather radar systems, systems with alternating pulses of horizontally and vertically polarized signals have been developed. These dual polarized radar system, sometimes referred to as “polarimetric weather radars,” offer several advantages over conventional radars in estimating precipitation types and amounts. Foremost among these advantages are the capability to discriminate between hail and rain, detect mixed phase precipitation, and estimate rainfall volume.

Current dual polarized radar systems utilize polarization that is altered sequentially between linear vertical and linear horizontal to capture data enhancing values, such as, for example: (1) reflectivity factors at both horizontal and vertical polarization; (2) differential reflectivity for two reflectivity factors; (3) cumulative differential phasing between the horizontally and vertically polarized echoes; (4) correlation coefficients between vertically and horizontally polarized echoes; and (5) linear depolarization ratios. In addition, Doppler velocity and spectrum width can be obtained by suitably processing the horizontally and vertically polarized return signals.

Dual polarized radar systems also allow for the implementation of precipitation classification schemes from inference radar processing of hydrometeor shapes as discussed in various papers authored by practitioners who work in these areas, such as, Ryzhkov, Liu, Vivekanandan, and Znic. In addition, by looking at phase differences between the horizontal and vertical components, the effects of partial beam blockage can be mitigated and greater clutter rejection can be obtained. However, the underlying assumption is that subsequent pulses (those of each polarization) are highly correlated and provide an effective velocity range reduced by a factor of two.

Another limitation of current alternating dual polarization radar systems is long dwell times and velocity range reductions. Any received reflection signal resulting from either polarization modes is assumed to come from the same scatterers (e.g. hydrometeors). In order to correlate the data from both the horizontally polarized and vertically polarized channels in current systems utilizing a waveguide switch, a single polarization pulse is transmitted followed by a period of delay (the dwell time) while reflections signals are being received. The opposing polarity pulse is subsequently sent and addi-

tional data is received by the same (single) receiver chain during a second dwell time. Reception of reflection signals, therefore, occurs during these two dwell periods during antenna rotation within a single beamwidth, resulting in a longer total dwell time for each beamwidth interrogation. Similarly, since the dwell time for each beamwidth interrogation (vertical+horizontal) is doubled, computational velocity perception is halved, thereby limiting the ability of current systems to resolve relatively high wind velocities in radar returns.

Improved dual polarization weather radar systems use simultaneous dual polarization modes to solve issues such as long dwell times and velocity range reductions instead of alternating polarization modes. Dual polarized systems, which propagate both a horizontal and a perpendicularly vertical wave simultaneously, have additional problems relating to the interference between the horizontal and vertical component. As shown in FIG. 1A, a dual polarized simultaneous wave **10** has a horizontal component **12** and a vertical component **14**. The two components are characterized by their amplitudes and the relative phase between them. When viewed along the direction of propagation, the tip of propagated wave vector of a fully polarized wave traces out a regular pattern of an ellipse. The shape of the ellipse is governed by the magnitudes and relative phase between the horizontal **12** and vertical components **14** of the wave. As the dual polarized elliptical wave **10** hits a reflective surface, the reflective surface can change the polarization of the wave **10** as it is reflected to be different from the polarization of the wave as it propagates. The radar antenna may be designed to receive the different polarization components of the wave **10** simultaneously. For example, the H and V (horizontal and vertical) parts of an antenna can receive the two orthogonal components of the reflected wave.

A radar system using H and V linear polarizations can thus have the following signals (or channels): HH—for signals that are horizontal transmit and horizontal receive, VV—for signals that are vertical transmit and vertical receive, HV—for signals that are horizontal transmit and vertical receive, and VH—for signals that are vertical transmit and horizontal receive. The HH and VV combinations are referred to as like-polarized, because the transmit and receive polarizations are the same. The HV and VH channels are cross-polarized because the transmit and receive polarizations are orthogonal to one another. The cross-polarized signals are created from a reflection that is not aligned perpendicularly with the direction of the propagation. As the reflection returns to the antenna at an angle other than parallel to the propagated angle, a portion of the horizontal signal results in a vertical component, and vice versa.

By examining the four signals, HH, VV, HV, and VH, all of the information necessary to describe the reflective source is captured. By examining the relative angle between the different signals and the power of the signals, the reflective source may be identified. The dual polarized radars of today, however, are unable to isolate and capture the different signals if the horizontal and vertical propagating signals are sent simultaneously.

SUMMARY OF THE INVENTION

An object of the invention provides a radar system comprising a waveform generator, amplifiers, an antenna and a receiver. The waveform generator is configured to generate a first signal and a second signal. The first signal having a different phase from the second signal. The amplifiers are configured to amplify the first and second signals. The

antenna is configured to simultaneously propagate the amplified first signal in a first plane and the amplified second signal in a second plane angularly rotated from the first plane. The receiver is configured to receive a first reflected signal having the phase of the first signal and a second reflected signal having a phase of the second amplified signal.

BRIEF DESCRIPTION OF THE DRAWINGS

FIGS. 1A and 1B are diagrams of a prior art propagation signal for a simultaneous dual polarization radar system having a horizontal and vertical signal;

FIG. 2 is a diagram of one embodiment of a simultaneous dual polarization radar system;

FIG. 3 is another diagram of one embodiment of a simultaneous dual polarization radar system; and

FIG. 4 is a block diagram of the steps performed in one embodiment of the simultaneous dual polarization radar system.

DETAILED DESCRIPTION OF THE DRAWINGS

Referring to the drawings, FIG. 2 shows a diagram of an embodiment of a simultaneous dual polarization radar system 20. An arbitrary waveform generator 22 generates an arbitrary waveform for the vertical and horizontal components at an intermediate frequency (IF) less than the transmitting frequency. The waveform in the arbitrary waveform generator 22 is passed to mixers 24A and 24B which combine the arbitrary waveforms with a stable local oscillator signal generated in a stable local oscillator 26. Amplifiers 28A and 28B amplify the signal from the mixers 24A and 24B and send the signals to an orthogonal feedhorn and antenna 30 for transmission.

The antenna and feedhorn 30 receive a scattered signal and transmit a horizontal and vertical scatter signal for processing in the radar system 20. Mixers 32A and 32B mix the vertical and horizontal components with the local stable oscillator signal from the local stable oscillator 26 to remove the local stable oscillator signal from the scatter signal. IF filters 34A and 34B filter the scattered IF signals based on the arbitrary waveform from the arbitrary waveform generator 22 and filter the signal to remove all signal contributions outside a tight range of frequencies centered around the intermediate frequency. The digital receiver board 36 receives the filtered scattered signal and the arbitrary waveform and transforms the filtered scattered signals into the baseband in-phase and quadrature signals for data processing.

The arbitrary waveform generator 22 may create an arbitrary waveform for each of the horizontal and vertical signals at an intermediate frequency less than the transmitting frequency. While the arbitrary waveform generator 22 may create an arbitrary signal for both the horizontal and vertical signals, the arbitrary waveform generator 22 may also create only one arbitrary waveform for only one of the horizontal and vertical signals. Whether one or two arbitrary waveforms is generated may be determined by a user who may access the arbitrary waveform generator 22. When the horizontal and vertical signals are propagated, both signals do not need to be modulated.

The arbitrary waveform generator 22 may capture a 'real world' signal using a DSO or digitizer, may create the waveform from a mathematical formula, may create the waveform graphically using drawing tools, or may construct the waveform from a library of waveform shapes. The arbitrary generator may use any of these methods, or a combination of these methods to create a waveform. As will be described

later, it is preferred that the arbitrary waveform generator 22 creates a pair of signals that are orthogonal to each other to maximize the cross polar independence of the horizontal and vertical signals.

The arbitrary waveform generator 22 may include some level of built-in waveform editing such as point-by-point value insertion, straight line interpolation between points or standard waveform insertion between points. However, complex arbitrary waveforms are more likely created outside of the generator and downloaded via the digital interfaces in the arbitrary waveform generator 22. The arbitrary waveform generator 22 creates the horizontal and vertical signals and sends these signals to the mixers 24A and 24B to combine the arbitrary waveform with a stable signal that when combined with the arbitrary waveform creates a signal having a frequency desired for transmission.

In one embodiment, the arbitrary waveform generator 22 also sends the arbitrary waveform to the IF Filters 34A and 34B. The arbitrary waveform generator 22 provides the arbitrary signal so that the IF filters 34A and 34B may filter higher frequency components from the received signal to a narrow frequency band centered at the IF frequency. In another embodiment, the IF filters 34A and 34B may filter the higher frequency components from the received signal to a narrow frequency band centered at the IF frequency without first receiving the arbitrary waveform from the IF filters 34A and 34B. Once the IF filters 34A and 34B have filtered the higher frequency components from the received signal, the filtered signal components are passed to the digital receiver board 36.

The arbitrary waveform generator 22 also passes the arbitrary waveform to the digital receiver board 36 so that the digital receiver board 36 may digitize the received IF signal and transform it into the baseband in phase and quadrature signals. The received, baseband filtered signal contains the characteristics of the hydrometeors that reflected the transmitted signal. As will be described below, the characteristics of the arbitrary waveform allow all of the polarimetric data to be retrieved in a simultaneous dual polarization weather radar system.

The stable local oscillator 26 generated a stable, low noise reference source at a frequency equal to the transmitted frequency minus the intermediate frequency of the arbitrary waveform. The signals are mixed to produce a signal at the transmitted frequency. Generally, the signal from the local oscillator 26 is a carrier signal that is combined with the arbitrary waveform to form a horizontal signal unique to the vertical signal, but both signals having a transmitting frequency desirable for weather identification.

The signal from the oscillator 26 is also injected into the mixers 32A and 32B with the received signal from the antenna 30 in order to effectively change the received signal by heterodyning it to produce the sum and difference of that received signal. The difference signal will be at the intermediate frequency of the arbitrary waveform, plus or minus any doppler shift in the received signal. Thus removing the stable, oscillating signal from the received signal. The received signal is then passed at a frequency close to the intermediate frequency to the IF filters 34A and 34B.

The amplifiers 28A and 28B receive the signal from the mixers 24A and 24B and amplify the signals to the power level desired for transmission. In this power amplifier embodiment, the amplifiers may be klystrons, TWTs, or other MOPAs. The size of the amplifiers 28A and 28B determines the maximum distance the transmitted signal can detect a reflector. The greater the amplification, the greater the dis-

tance a reflector may be detected. The amplifiers 28A and 28B feed the amplified signal to the orthogonal horn and antenna 30 for transmission.

The horn 30 transmits the signal out as a pair of orthogonal signals (the horizontal signal and the vertical signal) in the elliptical shape described in FIG. 1. When the horn 30 receives a reflected signal, it passes the horizontal received signal to mixer 32A and the vertical received signal to mixer 32B. As previously discussed, these mixers 32A and 32B downconvert the received signals with the local oscillator signal to beat a signal at the intermediate frequency for processing by the IF filters 34A and 34B.

The IF filters 34A and 34B receive the downconverted signal and use the arbitrary waveform to form the baseband signals for processing. The IF filter is tuned by the arbitrary waveform to remove all frequencies outside of a tight range of frequencies centered around the intermediate frequency. Thus, the IF filters 34A and 34B are passed the arbitrary waveform so that the IF filters 34A and 34B may set the intermediate frequency which creates the bandpass IF filter. Once the signal is filtered, and the signal left consists of the received horizontal and vertical arbitrary waveforms, then the signals are passed to the digital receiving board 36 for processing.

The digital receiving board 36 takes the horizontal and vertical received signals and generates the baseband in-phase and quadrature signals (I and Q signals.) These signals are the signals that determine the size, type, and direction of hydrometeors by giving the phase, frequency and amplitude of the received signals. The digital receiver board 36 takes the signals from the IF filters 34A and 34B and compares the information in those signals with the information in the arbitrary waveforms to calculate the I and Q signals of the received signals. As discussed below, the type of arbitrary waveforms generated in the arbitrary waveform generator 22 are chosen so that when the digital receiving board 36 captures the received signal, the board 36 can isolate the horizontal and vertical components (HH and VV) from the cross components (HV and VH).

The arbitrary waveforms are made up of a set of data values against time. A waveform could be captured from a 'real world' signal using a DSO or Digitizer. Alternatively, a waveform could be created from a mathematical formula, created graphically using drawing tools, or could be constructed from a library of waveform shapes. The arbitrary waveform generator 22 may use any of these of these methods. The arbitrary waveform generator 22 generates a pair of signals, a horizontal signal and a vertical signal, to send to the mixers 24A and 24B. The transmitted signal, then, may be characterized as a combination of these vertical and horizontal signals, or mathematically:

$$S_T = H_T \hat{H} + V_T \hat{V}$$

where S_T is the transmitted signal;
 H_T is the amplitude of the horizontally transmitted signal, as amplified in amplifier 28A;
 H is the horizontal vector;
 V_T is the amplitude of the vertically transmitted signal, as amplified in amplifier 28B; and
 V is the vertical vector.

The received signal will have a similar form, having a vertical and horizontal component, or mathematically:

$$S_R = H_R \hat{H} + V_R \hat{V}$$

where S_R is the received signal;
 H_R is the amplitude of the reflected horizontal signal;
 H is the horizontal vector;

V_R is the amplitude of the reflected vertical signal; and
 V is the vertical vector.

The received signal, however, in each polarization, is a combination of the horizontal and vertical transmitted signals. As previously discussed, this is because when the transmitted signal is reflected, the signal rotates. When this occurs, the orthogonal projections of the signal to the H and V vectors include components from both the horizontally transmitted and vertically transmitted signals. Mathematically, the two received signals can be described as:

$$H_R = \alpha H_T + \beta V_T \text{ and } V_R = \delta H_T + \gamma V_T$$

Where α , β , δ , γ are scalars related to the angular rotation of the horizontal and vertical signals and the proportion of the signal that is reflected back to the antenna 30. Thus, the scattering matrix of the received signal may be expressed as:

$$\begin{bmatrix} \alpha & \beta \\ \delta & \gamma \end{bmatrix}$$

and the matrix equation describing the received signal as a function of the transmitted signal may be expressed as:

$$\begin{bmatrix} H_R \\ V_R \end{bmatrix} = \begin{bmatrix} \alpha & \beta \\ \delta & \gamma \end{bmatrix} \begin{bmatrix} H_T \\ V_T \end{bmatrix}$$

The elements in the scattering matrix determine the cross polar received signal from the reflector. The diagonal terms are the amplitudes of the copolarized signals corresponding to the two transmitted polarizations, and the off-diagonal terms are the amplitudes of the cross-polarized signals. As can be seen in the equations, the ability to calculate the scalars determines whether good estimates for the horizontal and vertical components can be determined, which are the quantities desired for extrapolation of the base moment estimates.

Generally, either the horizontal, vertical or both signals may be shifted. The horizontal and vertical signals may not be shifted with the same phase information, because then the horizontal and vertical signals would again be identical. As long as four samples are taken from the received signal, a definite solution for the scattering matrix may be found. It may be possible to solve the scattering matrix using less sample points given the constraints of the system. Thus, because the scalars cannot exceed a value of 1, and the scalars for the horizontal signal, α and δ , are related through the rotation angle of the horizontal signal and the scalars for the vertical signal, β and γ , are related through the rotation angle of the vertical signal. Such that,

$$\alpha = H_{Rot} \cos \theta \text{ and } \delta = H_{Rot} \sin \theta$$

where H_{Rot} is the rotated, received horizontal signal; and θ is the angle of rotation of the horizontal signal.

Similarly, the scalars for the vertical signal may be expressed as,

$$\beta = V_{Rot} \cos \phi \text{ and } \gamma = V_{Rot} \sin \phi$$

where V_{Rot} is the rotated, received vertical signal; and ϕ is the angle of rotation of the vertical signal.

The rotated signals H_{Rot} and V_{Rot} are attenuated transmitted signals. The amplitude of H_{Rot} and V_{Rot} is less than the amplitude of the transmitted signals. Thus, H_{Rot} and V_{Rot} are constrained to be less than the amplitude of the original signal. Using this constraint, as well as the angular relationships

between α and δ and the angular relationship between β and γ , it may be possible to solve the scattering matrix using less than four samples from the received signal.

The rotated signals H_{Rot} and V_{Rot} may also be frequencies shifted when received. One source of frequency shift occurs from the doppler effect of a moving weather system. As the weather system moves relative to the weather radar system, the rotated signals H_{Rot} and V_{Rot} may be shortened (i.e., shift to a higher frequency) or may be lengthened thereby being received at a lower frequency. Another frequency shift may occur because of the size asymmetry of a raindrop with respect to the horizontal and vertical planes. Because the raindrop elongates in the horizontal plane, there may be a shift in the horizontal plane. By measuring the frequency shift and accounting for the relative change in frequency between the horizontal and vertical frequencies, the contributions of the horizontal and vertical transmitted signals may be isolated within the weather radar system 10.

In a preferred embodiment, the arbitrary waveform generator 22 generates a pair of signals that are phase shifted such that the signals are orthogonal to each other. One of the orthogonal signals is sent on the horizontal transmission path and the other signal on the vertical transmission path. By defining two functions that are orthogonal, the components of the horizontal signal contributed through the vertically transmitted signal and the components of the vertical signal contributed through the horizontally transmitted signal may be isolated in the received signals so that the horizontal and vertical components are completely recovered. Mathematically,

$$H_R = \Psi_H \alpha H_T + \Psi_V \beta V_T \text{ and } V_R = \Psi_H \delta H_T + \Psi_V \gamma V_T$$

Where Ψ_V and Ψ_H are the phase shifting for the horizontal and vertical signals. When the signals are phase shifted, the signals will obey these equations:

$$\int_a^b \Psi_V(t) \Psi_H(t) dt = 0$$

and

$$\Psi_H^{-1} \Psi_V = \Psi_V^{-1} \Psi_H = 0$$

the signals can be used to reduce the equations in the scattering matrix to single equations as opposed to a system of equations that are simultaneously solved in matrix form.

Using the properties that:

$$\int_a^b \cos(t) \sin(t) dt = 0 \text{ and } \cos(t) = \sin(t - \frac{\pi}{2})$$

the phase shifting should be:

$$|\Psi_H - \Psi_V| = \pi/2$$

When the phase shifts in the horizontal and vertical signals are passed through the two equations for received horizontal and vertical signals, the equations simplify to:

$$H_R = \beta V_T \text{ and } H_R = \alpha H_T$$

and

$$V_R = \gamma V_T \text{ and } V_R = \delta H_T$$

when the signal is sampled at times equal to $\pi/2, \pi, 3\pi/4$, and 2π of the cycle of one transmitted signal. V_T, H_T, V_R, H_R , are

all known, the scalars in the scattering matrix may be determined from these four equations. Thus, in the case of orthogonally shifted horizontal and vertical signals, the processing required to determine the scattering matrix is minimized.

Turning now to FIG. 3, FIG. 3 shows another diagram of a simultaneous dual polarization radar system 40 using a single transmitter. A stable local oscillator 42 generates a stable local oscillator signal. A power component 44 amplifies the stable local oscillator signal. A power divider 46 splits the amplified signal into two identical signals. High powered waveguide components 48A and 48B modulate the signal with one arbitrary waveform for the vertical and one arbitrary waveform for the horizontal component. An orthogonal feedhorn and antenna 50 transmit the modulated signal into air.

Similar to the system of FIG. 2, the antenna and feedhorn 50 receive the scattered signal and transmit a horizontal and vertical scatter signal for processing in the radar system 40. Mixers 52A and 52B mix the vertical and horizontal components with the local stable oscillator signal from the local stable oscillator to remove the local stable oscillator signal from the scatter signal. IF filters 54A and 54B filter the scattered IF signals to a narrow frequency band centered at the IF frequency. A digital receiver board 56 receives the filtered scattered signal and the signal modulation and processes the baseband in-phase and quadrature signals for data processing.

Many of the parts in the power oscillation radar system 40 behave in the same manner as the similar components in FIG. 2. The processing of the scattered signal is the same, and includes all of the same components. The difference in the systems of FIG. 2 and FIG. 3 is the difference in the generation of the transmitted signal. Both systems use a stable oscillator to form a portion of the transmitted signal and an orthogonal feed horn and antenna to propagate orthogonal vertical and horizontal components. The power component 44 of FIG. 3 may be a power amplifier such as that of a MOPA system or, in a different embodiment, a power oscillator such as a magnetron. In a MOPA system, the stable local oscillator 42 passes the signal for amplification to a power amplifier. In a power oscillator system, the stable local oscillator 42 generates a signal at a frequency equal to the transmitted frequency minus the IF frequency. The signal from the stable local oscillator 42 is mixed with the received signal to produce the IF frequency signal.

Other components are generally similar but are used slightly differently. In the single transmitter simultaneous dual polarization radar system of FIG. 3, such as a magnetron based system, the shifted signal is not introduced into the system until after the amplification. In the dual transmitter power amplifier system of FIG. 2, the reference signal is modulated prior to amplification. Where a pair of amplifiers are used in the power amplifier system, only one amplifier is used in the power amplifier system. Additionally, the single transmitter system 40 includes a power divider 46 and a pair of power waveguide components 48A and 48B.

The power divider 46 takes the single, amplified signal from the amplifier or power oscillator 44 and divides the signal into two identical signals. Because the power is halved for each signal, the high power component 44 outputs a signal that is larger than the amplifiers in FIG. 2 to meet the same power specifications for the antenna. The two identical wave signals leave the power divider 46 and enter the high power waveguide components 48A and 48B.

The high power waveguide components 48A and 48B shift the identical signals similar to the function of the arbitrary waveform generator in FIG. 2. The high power waveguide components 48A and 48B (which are high powered shifting

devices) may be a resonant cavity that shifts the wave according to the desired shifting. In one embodiment, the shift may be generated within the receiver 56 or a signal processor. The shift may also be preprogrammed into high power shifting devices 48A and 48B or mechanically based on the structure of the preprogrammed devices.

While the embodiment of FIG. 3 uses a pair of high power shifting devices 48A and 48B, another embodiment may only have a single high power shifting device. With a single high power shifting device, one of the signals would be shifted and the other signal would be left alone. The signal modulated may be either the vertical or horizontal signal. Regardless whether one or two high power shifting devices 48A and 48B are used, the shifted signal from the high power devices 48A and 48B are also sent to the receiving elements which process the received signal.

The shifted signal is sent to the IF filters 54A and 54B as well as the digital receiving board 56. Similar to the configuration of FIG. 2, the IF filters 54A and 54B filter the received signal to a narrow frequency band around the IF frequency for processing in the digital receiving board 56. The digital receiving board 56, as discussed above, uses the shifted signal from the high power devices 48A and 48B to process the filtered IF signal from the IF filters 54A and 54B. In this manner, the shifted signal from the high power devices 48A and 48B serve as the transmitted horizontal and vertical signals for processing.

Turning now to FIG. 4, FIG. 4 is a block diagram of the steps performed in one embodiment of the simultaneous dual polarization radar system. The method starts in Step 60. Horizontal and vertical pulses are generated in step 62. The horizontal and vertical signals are shifted in step 64. In step 66, the shifted signals are transmitted. The vertical and horizontal scattered signals are received by the radar system in step 68. The vertical and horizontal signals are downconverted in step 70 to remove a stable oscillating signal from the received signal so that the intermediate frequency signal is left. The IF signal is transferred in step 72 and processed to the baseband signals in step 74. The baseband signals are sent to a signal processor in step 76 and decoded in step 78 using the shifting from the transmitted signal to determine the values within the scattering matrix. The vertical and horizontal received signals are isolated and the polarimetric data is calculated in step 80. The method ends in step 82.

By implementing the method of FIG. 4, a polarimetric radar system may simultaneously send vertical and horizontal components in a transmitted signal and isolate the vertical and horizontal components to process the data received in both the horizontal and vertical components resolved using signals in both the horizontal and vertical planes. The method also decreases the long dwell times of polarimetric radar systems which switches between sending a single horizontal or vertical signal. By using a simultaneous dual system, the velocity characteristics of the reflectors may also be resolved with higher specificity because the delay between receiving like signals is halved.

While the invention has been shown in embodiments described herein, it will be obvious to those skilled in the art that the invention is not so limited but may be modified with various changes that are still within the spirit of the invention.

Having set forth the nature of the invention, what is claimed is:

1. A radar system, comprising:

- a. a sole arbitrary waveform generator configured to generate a first signal and a second signal, said first signal having a different phase from said second signal;

- b. a pair of signal mixers, one said signal mixer electrically coupled to an output of said waveform generator and said other mixer electrically coupled to an output of said waveform generator;
- c. a local oscillator electrically coupled to said pair of signal mixers such that said first and second signals are heterodyned with a signal from said local oscillator;
- d. a pair of amplifiers configured to amplify the output from said pair of signal mixers;
- e. a single orthogonal horn and antenna assembly coupled to said pair of amplifiers and configured to simultaneously propagate said amplified and heterodyned first signal in a first plane and said amplified and heterodyned second signal in a second plane angularly rotated from said first plane;
- f. a second pair of mixers electrically coupled to and arranged with said orthogonal horn and antenna assembly such that said second pair of mixers receives orthogonally oriented reflectivity signals received from said horn and antenna assembly, wherein each of said second pair of mixers is electrically coupled to said local oscillator such that said second pair of mixers mixes said orthogonally oriented reflectivity signals with said local oscillator signal;
- g. a pair of intermediate frequency filters each coupled to one of said second pair of mixers; and,
- h. a receiver coupled to both of said intermediate frequency filters, said receiver including means for resolving the scattering matrix associated with said orthogonally oriented received reflectivity signals and wherein said resolving means is configured to produce polarimetric data from reflectivity signals having a phase of said first signal and reflectivity signals having a phase of said second signal.
2. The radar system of claim 1, wherein said resolving means further comprises means to calculate the phase relationship between the first and second signals in accordance with the equation:

$$|\Psi_H - \Psi_V| = \pi/2.$$

3. The radar system of claim 1, wherein said arbitrary waveform generator is configured to shift said first signal orthogonally relative to said second signal at random intervals.

4. The radar system of claim 1, wherein said arbitrary waveform generator is configured to generate a first arbitrary waveform comprising said first signal and a second arbitrary waveform comprising said first signal, each waveform formed at an intermediate frequency less than the frequency of said propagated first and second signals, and wherein said waveform generator is further configured such that said first and second arbitrary waveforms are different from one another.

5. The radar system of claim 1, wherein said receiver is further configured to receive said first and second signals from said waveform generator.

6. The radar system of claim 5, wherein said receiver includes means for isolating said first and second reflected signals by comparing said first and second received signals to said first and second signals received from said waveform generator.

7. The radar system of claim 6 wherein:

- a. said orthogonal horn and antenna assembly is further configured to receive a first planar signal including a portion of said first reflected signal and a portion of said second reflected signal;

11

- b. said orthogonal horn and antenna assembly is further configured to receive a second planar signal including a portion of said first reflected signal and a portion of said second reflected signal; and
- c. said receiver is further configured to calculate an angular rotation of said first and second reflected signal from said first and second plane.
- 8.** A method for processing simultaneous dual polarized signals from a radar system, comprising the steps of:
- generating horizontal and vertical pulses;
 - shifting said vertical pulse signals relative to said horizontal pulse signals such that said signals have disparate phases;
 - mixing said shifted signals with a local oscillator signal;
 - propagating said mixed vertical and horizontal pulse signals through an orthogonal horn and antenna assembly into space;
 - receiving a first signal from a reflected source, said first received signal including a portion of said mixed vertical pulse signal and a portion of a said mixed horizontal pulse signal, wherein said vertical pulse signal is shaped differently than said horizontal pulse signal;
 - receiving a second signal from a reflected source, said second received signal including a portion of said first mixed vertical pulse signal and a portion of said mixed horizontal pulse signal; and
 - decoding said first and second received signals by comparing said first mixed vertical pulse signal and said mixed horizontal pulse with said first and second received signals.
- 9.** The method of claim **8**, further comprising the step of comparing said second transmitted signal with said first and second received signals.
- 10.** The method of claim **9**, further comprising receiving said first and second received signals simultaneously.
- 11.** The method of claim **8** wherein said first transmitted signal is orthogonal to said second transmitted signal.
- 12.** The method of claim **11**, wherein said first transmitted signal and said first received signal are located in a first plane and said second transmitted signal and said second received signal are located in a second plane.
- 13.** The method of claim **12**, wherein said first plane is orthogonal to said second plane.
- 14.** A radar system comprising:
- a sole local oscillator configured to generate a low power signal;
 - an amplifier configured to amplify said low power signal to a high power signal;
 - a power divider configured to split said high power signal into a first signal and a second signal;
 - a high powered shifting device configured to shift said first signal;
 - an orthogonal horn and antenna assembly coupled to said power divider and configured to simultaneously propagate said first signal in a first plane and said second signal in a second plane angularly rotated from said first plane, wherein said first plane is orthogonal to said second plane; and
 - a second pair of mixers electrically coupled to and arranged with said orthogonal horn and antenna assembly such that said second pair of mixers receives orthogonally oriented reflectivity signals received from said horn and antenna assembly, wherein each of said second pair of mixers is electrically coupled to said local oscillator such that said second pair of mixers mixes said orthogonally oriented reflectivity signals with said local oscillator signal;

12

- a pair of intermediate frequency filters each coupled to one of said second pair of mixers; and,
 - a receiver coupled to both of said intermediate frequency filters, said receiver including means for resolving the scattering matrix associated with said orthogonally oriented received reflectivity signals and wherein said resolving means is configured to receive a first reflected signal having the shape of said first signal and a second reflected signal having a shape of said second signal.
- 15.** The radar system of claim **14**, wherein said receiver further comprises means to calculate the phase relationship between the first and second signals in accordance with the equation:
- $$|\cap_H - \cap_V| = \pi/2.$$
- 16.** The radar system of claim **14**, wherein said local oscillator is configured to shift said first amplified signal from said second amplified signal.
- 17.** The radar system of claim **14**, further comprising a second high powered shifting device configured to shift said second amplified signal wherein said oscillator generates said first and second signals at an intermediate frequency less than the frequency of said propagated first and second signals.
- 18.** The radar system of claim **14**, wherein said first and second phase shifts are sent to said receiver.
- 19.** The radar system of claim **14**, wherein said receiver is coupled to said high powered shifting and further configured to receive said phase shifts from said high powered shifting device.
- 20.** The radar system of claim **19**, wherein said receiver isolates said first and second reflected signals by comparing said first and second received signals to said phase shift.
- 21.** The radar system of claim **20** wherein:
- said orthogonal horn and antenna assembly is further configured to receive a first planar signal including a portion of said first reflected signal and a portion of said second reflected signal;
 - said orthogonal horn and antenna assembly is further configured to receive a second planar signal including a portion of said first reflected signal and a portion of said second reflected signal; and
 - said receiver is further configured to calculate an angular rotation of said first and second reflected signal from said first and second plane.
- 22.** A method for propagating simultaneous dual polarized signals from a radar system, comprising the steps of:
- generating a first signal and a second signal;
 - shifting said first signal such that said first signal and said second signal are phased differently;
 - heterodyning said first and second signals with a local oscillator; and,
 - propagating said first signal on a first plane and said second signal on a second plane through an orthogonal horn and antenna assembly into space, wherein said second plane is rotated from said first plane.
- 23.** The method of claim **22**, wherein said first plane is orthogonal to said second plane.
- 24.** The method of claim **22**, further comprising propagating said first and second signals simultaneously.
- 25.** The method of claim **22** wherein said first signal is orthogonal to said second signal.
- 26.** The method of claim **25**, wherein said first signal and a first received signal are located in said first plane and said second signal and a second received signal are located in said second plane.
- 27.** The method of claim **26**, wherein said first plane is orthogonal to said second plane.

13

28. The method of claim **27**, further comprising:

- a. decoding said first and second received signals by comparing said first signal with said first and second received signals,
- b. wherein said first received signal includes a portion of a first transmitted signal and a portion of a second transmitted signal; and
- c. said second received signal includes a portion of said first transmitted signal and a portion of said second transmitted signal.

14

29. The method of claim **28**, further comprising the step of comparing said second transmitted signal with said first and second received signals.

30. The method of claim **29**, further comprising receiving said first and second received signals simultaneously.

* * * * *